

# SPECIFICATION FOR APPROVAL

**DESCRIPTION:** 10.9"LCD Display  
**CUSTOMER:** BR109-I4018J30A1 V.1  
**Product No:** \_\_\_\_\_  
**Released Date:** 2023.03.10  
**Revision:** v1

PLEASE RETURN TO US ONE COPY OF "SPECIFICATION FOR APPROVAL" WITH YOUR APPROVED SIGNATURES.

APPROVED SIGNATURES		

Ⓟ

### Record of Revision

Version	Revise Date	Page	Content
Pre-spec.A	2023/03/10		Initial Release

## TABLE OF CONTENTS

No.	CONTENTS	PAGE
	REVISION STATUS.....	1
	TABLE OF CONTENTS.....	3
1.	GENERAL DESCRIPTION.....	4
2.	MECHANICAL SPECIFICATION.....	5
3.	PIN DESCRIPTION.....	6
4.	ELECTRICAL CHARACTERISTICS.....	7
5.	INPUT SIGNAL TIMING.....	10
6.	OPTICAL CHARACTERISTICS.....	13
7.	RELIABILITY TEST ITEMS.....	15
8.	GENERAL PRECAUTION.....	16

## 1. GENERAL DESCRIPTION

### 1.1 DESCRIPTION

This LCM is a color active matrix thin film transistor (TFT) IPS liquid crystal display (LCD) that uses amorphous silicon TFT as a switching device. It is composed of a TFT LCD panel, Driver IC, FPC and Backlight, This TFT LCD has a 10.9 inch diagonally measured active display area with (1480horizontal by 320 vertical pixel) resolution.

### 1.2 FEATURES:

No.	Item	Specification	Unit
1	Panel Size	10.9"	inch
2	Number of Pixels	320(H)×1480(V)	pixels
3	Active Area	57.984(H) ×268.176(V)	mm
4	Pixel Pitch	0.1812(H)×0.1812(V) x RGB	mm
5	Outline Dimension	65.00(W)×282.00(H)×4.50 (D)	mm
6	Number of Colors	16.7M	-
7	Display Mode	Transmission mode, normally black	-
8	Viewing Direction	Full viewing	-
9	Display Format	RGB vertical stripe	-
10	Surface Treatment	Glare	-
11	Interface	MIPI	-
12	Backlight	White LED	-
13	Operation Temperature	-20~70	°C
14	Storage Temperature	-30~80	°C
15	Weight	120	g

## 2. MECHANICAL SPECIFICATION

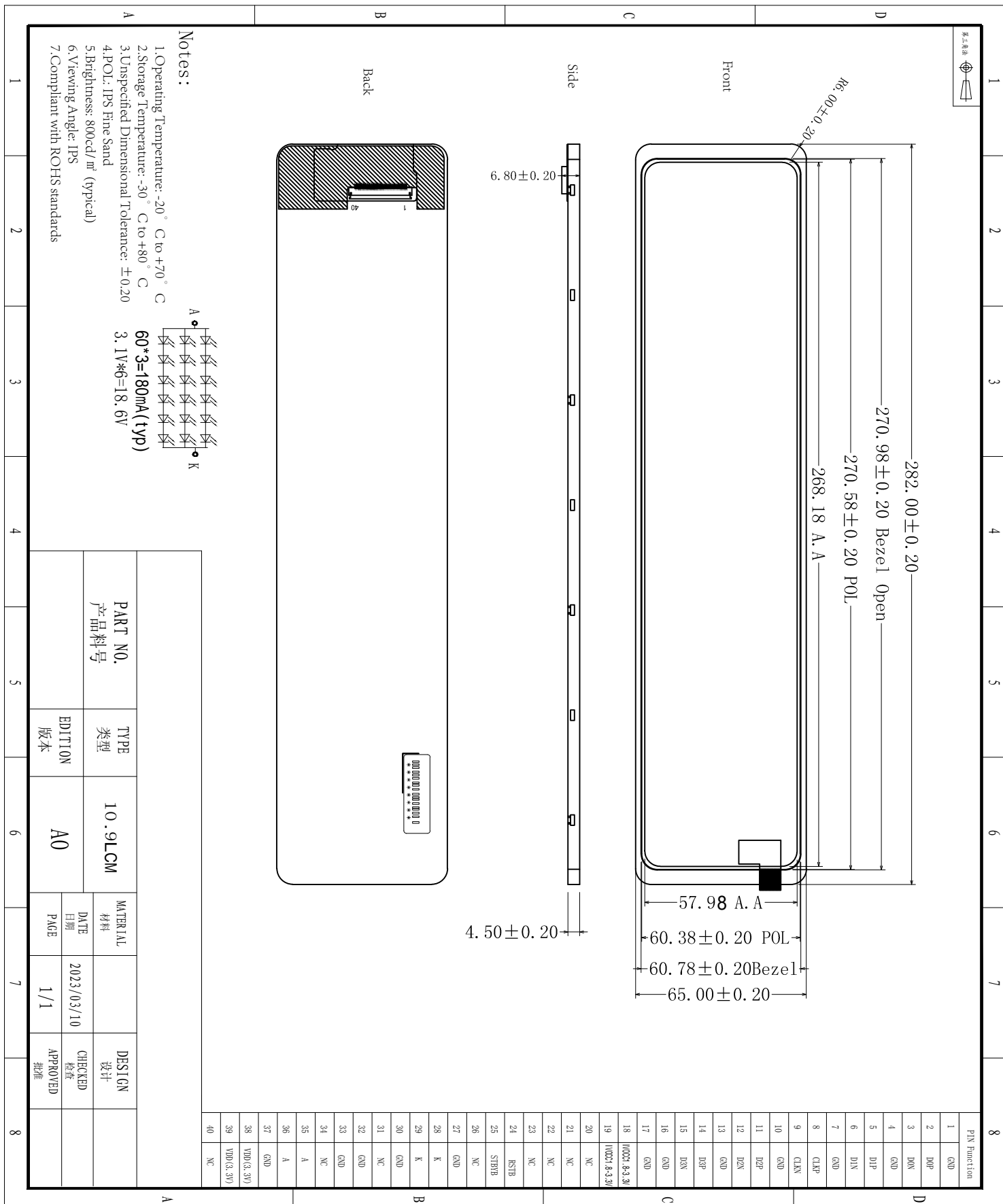

### 3. PIN DESCRIPTION

FPC Connector is used for the module electronics interface.

No.	Symbol	Function	Remark
1	GND	Ground	
2	D0P	Positive MIPI differential data input	
3	D0N	Negative MIPI differential data input	
4	GND	Ground	
5	D1P	Positive MIPI differential data input	
6	D1N	Negative MIPI differential data input	
7	GND	Ground	
8	CLKP	Positive MIPI differential clock input	
9	CLKN	Negative MIPI differential clock input	
10	GND	Ground	
11	D2P	Positive MIPI differential data input	
12	D2N	Negative MIPI differential data input	
13	GND	Ground	
14	D3P	Positive MIPI differential data input	
15	D3N	Negative MIPI differential data input	
16	GND	Ground	
17	GND		
18	IOVCC1.8V-3.3V	A power supply for the analog power.	
19	IOVCC1.8V-3.3V		
20	NC	No connection	
21	NC	No connection	
22	NC	No connection	
23	NC	No connection	
24	RSTB	Reset pin.	
25	STBYB	Standby mode control.	
26	NC	No connection	
27	GND	Ground	
28	K	LED Cathode	
29	K		
30	GND	Ground	
31	NC	No connection	
32	GND	Ground	
33	GND	Ground	
34	NC	No connection	
35	A	LED Anode	
36	A		
37	GND	Ground	
38	VDD(3.3V)	A power supply for the analog power.	
39	VDD(3.3V)		
40	NC	No connection	

## 4. ELECTRICAL CHARACTERISTICS

### 4.1 ABSOLUTE MAXIMUM RATINGS

Item	Symbol	Values		Unit	Remark
		Min.	Max.		
Digital Supply Voltage	VCI	-0.3	4.0	V	
Digital Supply Voltage	IOVCC	-0.3	4.0	V	

### 4.2 TFT LCD MODULE

#### 4.2.1 Operating Conditions

Item	Symbol	Values			Unit	Remark
		Min.	Typ.	Max.		
Digital Supply Voltage	VDD	3.0	3.3	3.6	V	
Digital Supply Voltage	IOVCC	1.6	-	3.6	V	
Logic Input Voltage	VIH	0.7VDD	-	VDD	V	
	VIL	GND	-	0.3VDD	V	

Note1: Please adjust VCOM to make the flicker level be minimum

Note2: TYP VCOM is only reference value. It must be optimized according to each LCM. Be sure to use VR and OP buffer on VCOM output. Please adjust VCOM to make the flicker level be minimum for getting excellent image.

#### 4.2.2 Current Consumption

Item	Symbol	Condition	Values			Unit	Remark
			Min.	Typ.	Max.		
Digital Current	IVCI	VDD= 3.3V	-	130	-	mA	Note1

Note1: Typ. specification: Gray-level test Pattern

4 3 BACKLIGHT UNIT

Item	Symbol	Values			Unit	Remark
		Min.	Typ.	Max.		
LED Current	Iled	-	180	240	mA	Total LED
Forward voltage	VF	-	18.6	-	V	

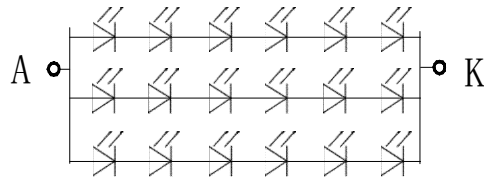

$$60 \times 3 = 180 \text{mA (typ)}$$

$$3.1 \text{V} \times 6 = 18.6 \text{V}$$

## 4.4 POWER ON/OFF SEQUENCE

### POWER ON SEQUENCE

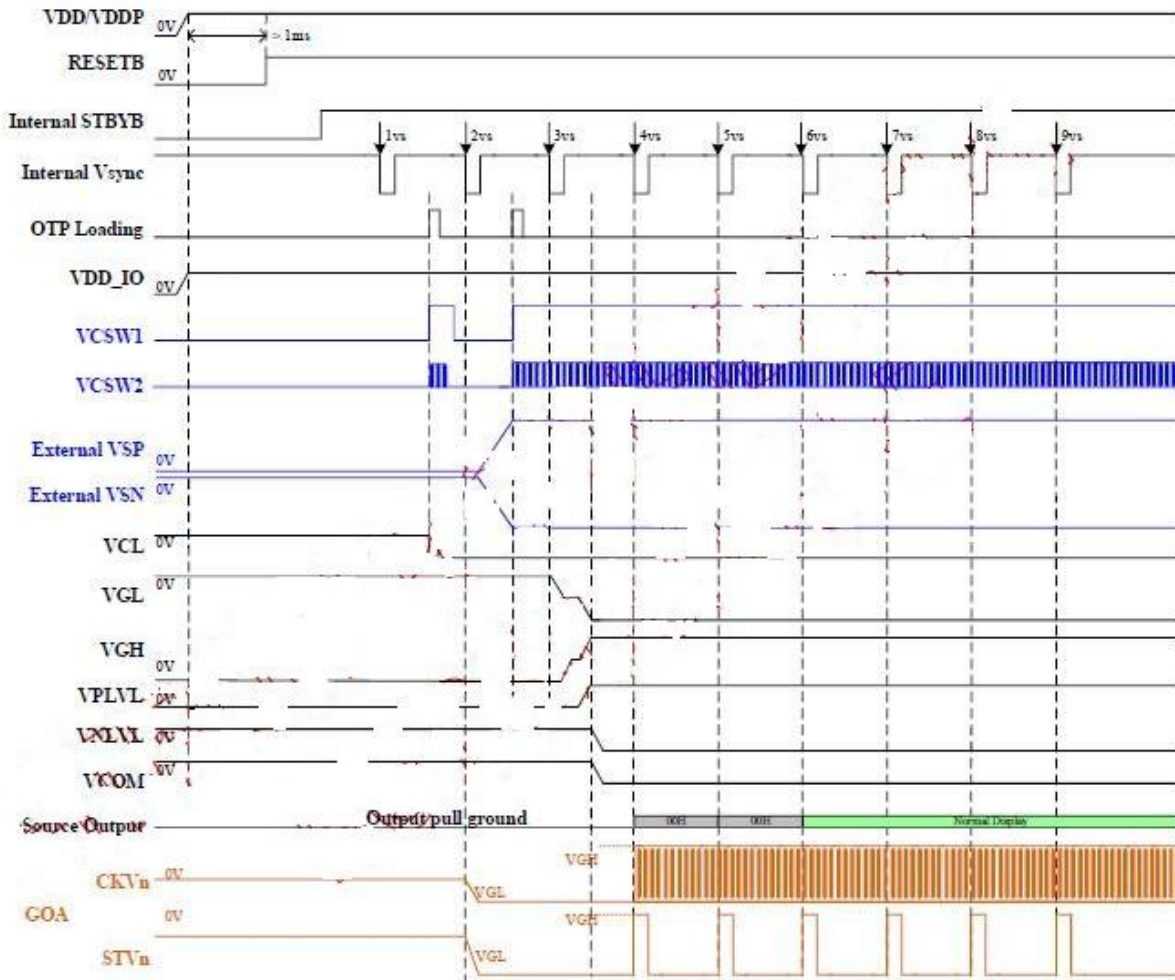

### POWER OFF SEQUENCE

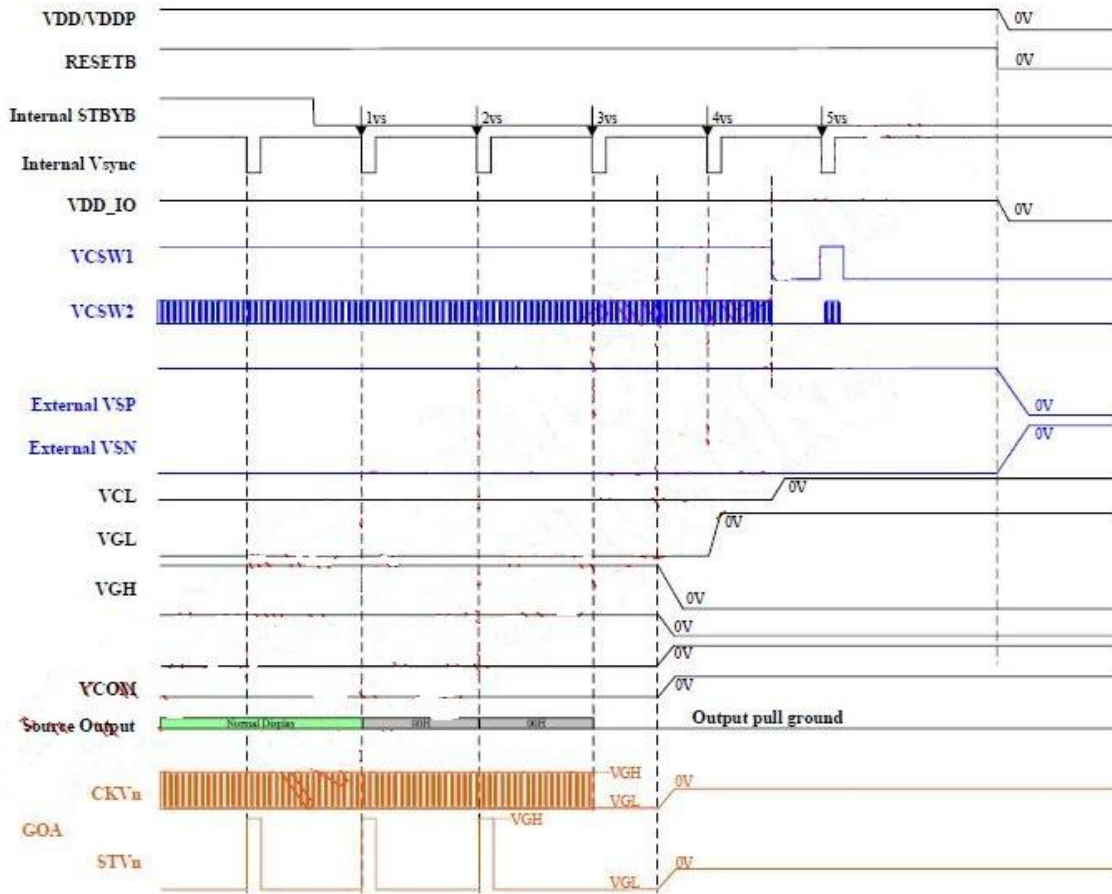

## 5. INPUT SIGNAL TIMING

### 5.1 MODE DC ELECTRICAL CHARACTERISTICS

(Test condition: VCI=1.6~3.6V, TA=-20°C~+85°C, VSS=VSSA=0V)

Parameter	Symbol	Spec.			Unit	Note
		Min.	Typ.	Max.		
VDDIO Input high level voltage	VIH	0.8 x VDDIO		VDDIO	V	
VDDIO input low level voltage	VIL	VSS		0.2 x VDDIO	V	
Input Leakage Current	Ileak	(-1)		(+1)	μA	
VGL_REG2 output voltage	VGL_REG2		TBD		V	
VGMP output voltage	VGMP		TBD		V	
VGMN output voltage	VGMN		TBD		V	
VCI1 output voltage	VCI1		TBD		V	
VGL output voltage	VGL_Q	-16		-6	V	
VGH output voltage	VGH_Q	8		19	V	
VCL output voltage	VCL	-2.1	-2.4	-3	V	
VOM output voltage	VCOM	-2.75	-1.48	-0.2	V	
Input terminal resistance	ZID		100		ohm	
Source output level deviation	Graycode = 0 ~ 14 Graycode = 241 ~ 255		TBD		mV	
	Graycode = 15 ~ 31 Graycode = 208 ~ 240		TBD		mV	
	Graycode = 32 ~ 207		TBD		mV	
Source output offset deviation	Graycode = 0 ~ 14 Graycode = 241 ~ 255	-	TBD		mV	
	Graycode = 15 ~ 31 Graycode = 208 ~ 240	-	TBD		mV	
	Graycode = 32 ~ 207	-	TBD		mV	
Current consumption	Analog Operating	IAOP	TBD		mA	
	Analog Stand-by	IAST	TBD		mA	
Rush current	Ivddpeak		TBD		mA	
VOTP operation current	Ivpp		TBD		mA	

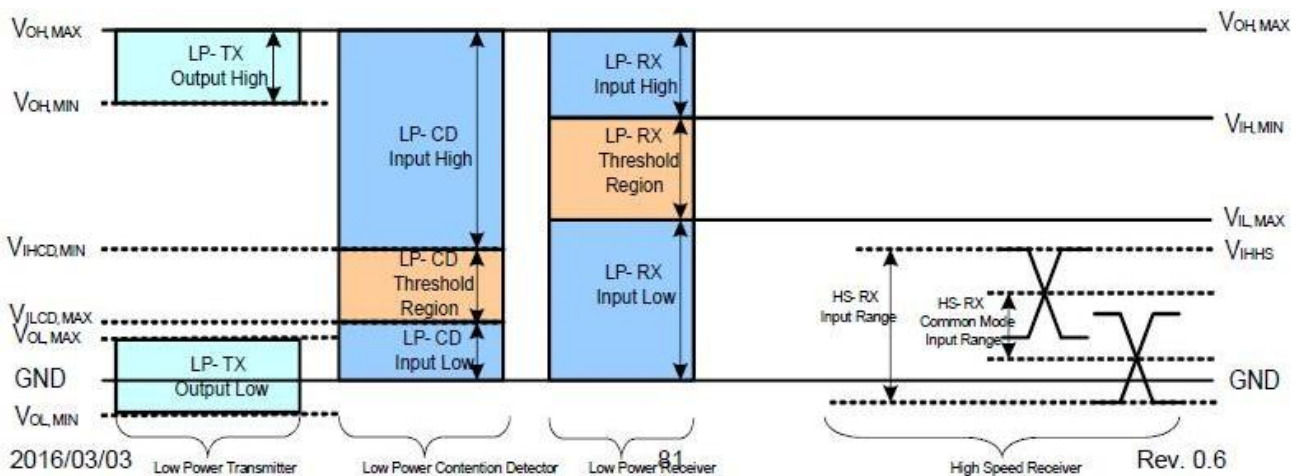

## 5.2 AC CHARACTERISTICS

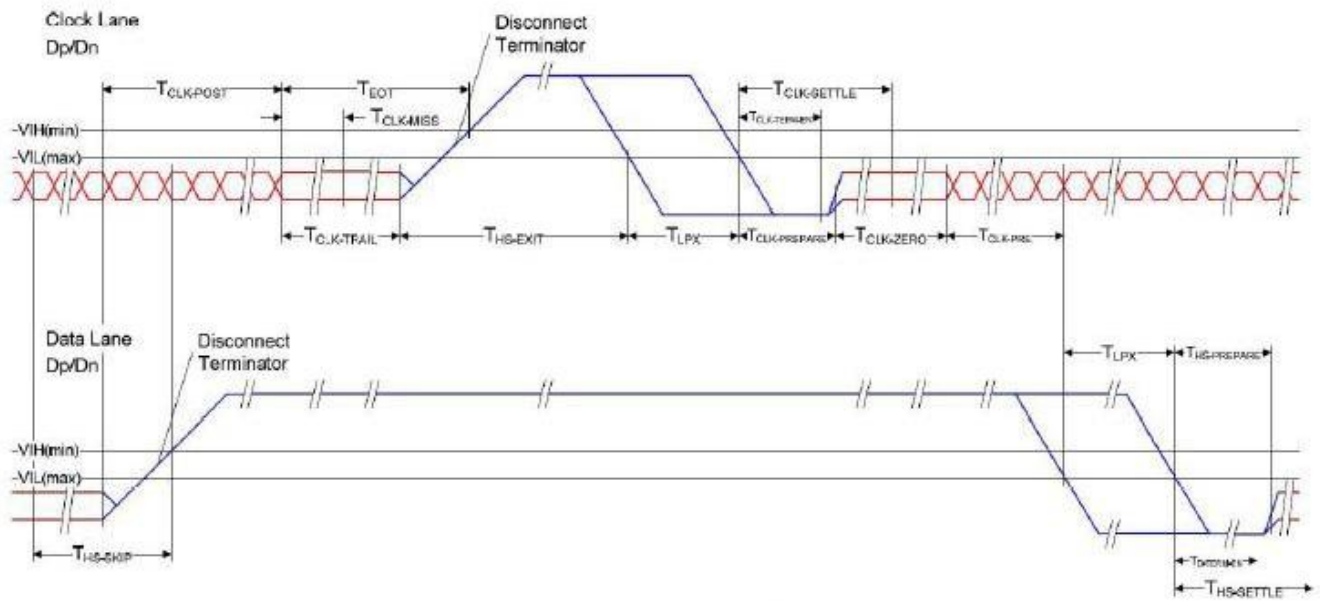

Figure 13.1: Switching the clock lane between clock transmission and low-power mode

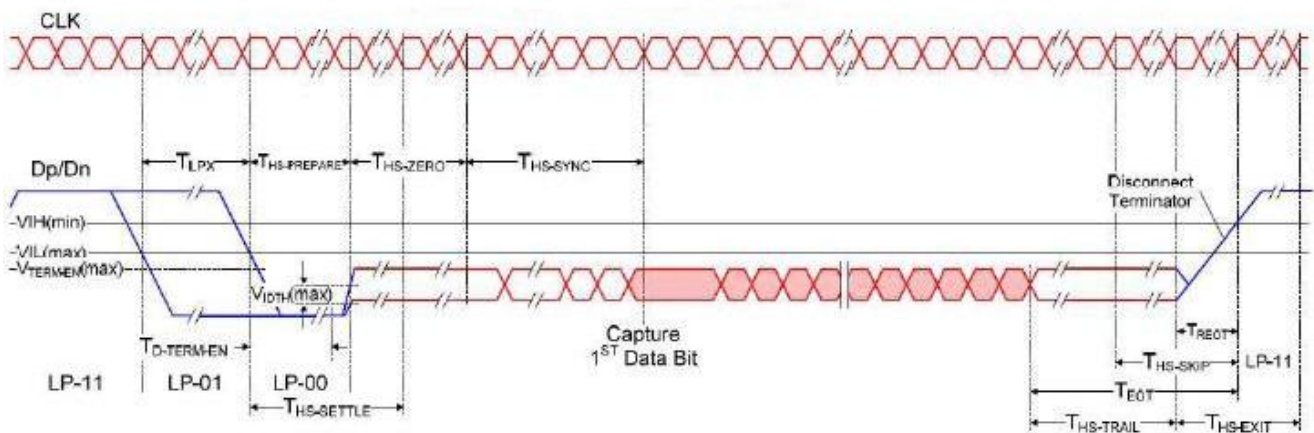

Figure 13.2: Timing of high-speed data transmission in bursts

### 5.3 PARALLEL RGB INPUT TIMING TABLE

Parameter	Symbol	Spec.			Unit
		Min.	Typ.	Max.	
Horizontal Display Area	thd	320			DCLK
One Horizontal Line	th	-	824	-	DCLK
HS pulse width(HSYNC)	thpw	-	23	-	DCLK
Hs Back Porch(Blanking)	thbp	240			DCLK
Hs Front Porch	thfp	53			DCLK
Parameter	Symbol	Spec.			Unit
		Min.	Typ.	Max.	
Vertical Display Area	tvd	1480			TH
VS Period	tv	-	1680	-	TH
VS Pulse Width(VSYNC)	tvpw	-	4	-	TH
VS Back Porch(Blanking)	tvbp	12			TH
VS Front Porch	tvfp	-	16	-	TH
Parameter	Symbol	Spec.			Unit
		Min.	Typ.	Max.	
MIPI(4 Lane)@Frame rate=60Hz			386		Mbps
MIPI(3 Lane)@Frame rate=60Hz			515		Mbps
DCLK frequency@Frame rate=60Hz	F <sub>DCLK</sub>		40		MHz

### 6. OPTICAL CHARACTERISTICS

Ta=25±2℃

Item	Symbol	Min.	Typ.	Max.	Unit	Note	
Contrast Ratio	CR	-	900	-		Note1 Note3	
Luminance(center)	L	-	800	-	cd/m2	Note1 Note5 Note7	
Luminous tolerance	LU	80	85		%	Note7	
Response Time	Rising + Falling	-	30	35	ms	Note1 Note4	
Viewing Angle K=Contrast Ratio>10	Horizontal	θx <sup>+</sup>	80	85	-	degree	Note2
		θx <sup>-</sup>	80	85	-		
	Vertical	θy <sup>+</sup>	80	85	-		
		θy <sup>-</sup>	80	85	-		
Color Chromaticity (CIE1931)	Red	x	Typ- 0.05	0.592	Typ+ 0.05	Note1 Note5 Note7	
		y		0.321			
	Green	x		0.289			
		y		0.609			
	Blue	x		0.139			
		y		0.076			
	White	x		0.270			
		y		0.298			
Color gamut (NTSC ratio)		-	65		%		

Note1: Definition of optical measurement system (BM-7)

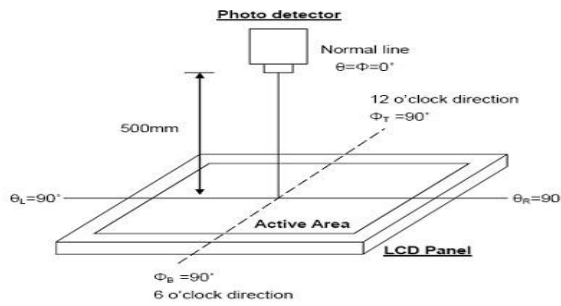

Note2: Definition of viewing angle range and measurement system

Viewing angle is measured at the center point of the LCD by CONOSCOPE (ergo-80).

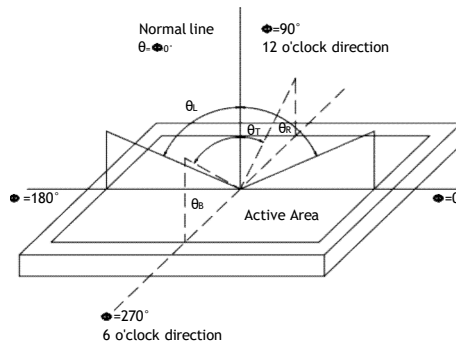

Note3: Definition of Response time

The response time is defined as the LCD optical switching time interval between “White” state and “Black” state. Rise time (TON) is the time between photo detector output intensity changed from 90% to 10%. And fall time (TOFF) is the time between photo detector output intensity changed from 10% to 90%.

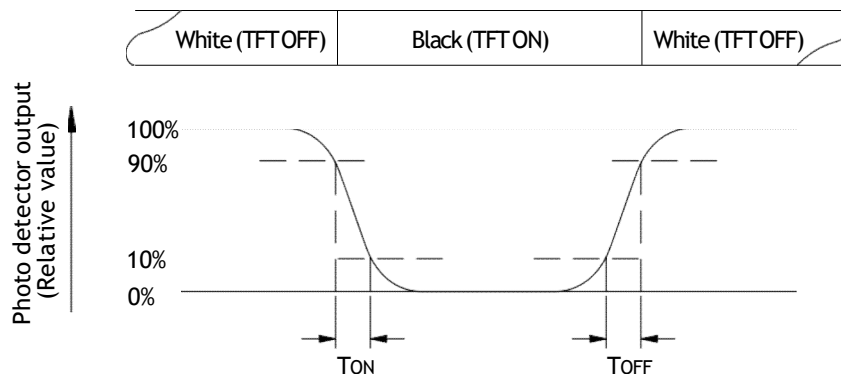

Fig. 6-3 Definition of response time

Note4: Definition of contrast ratio

$$\text{Contrast ratio (CR)} = \frac{\text{Luminance measured when LCD on the Whitestate}}{\text{Luminance measured when LCD on the Blackstate}}$$

“White state “: The state is that the LCD should drive by  $V_{white}$ .

“Black state”: The state is that the LCD should drive by  $V_{black}$ .

$V_{white}$ : To be determined  $V_{black}$ : To be determined.

Note5: Definition of color chromaticity (CIE1931)

Color coordinates measured at center point of LCD.

Note6: All input terminals LCD panel must be ground while measuring the center area of the

panel. The LED driving condition is  $I_L=120mA$

**Note7: Definition of Luminance Uniformity**

Active area is divided into 9 measuring areas. Every measuring point is placed at the center of each measuring area.

Luminance Uniformity (U) =  $L_{min} / L_{max}$

L-----Active area length, W----- Active area width

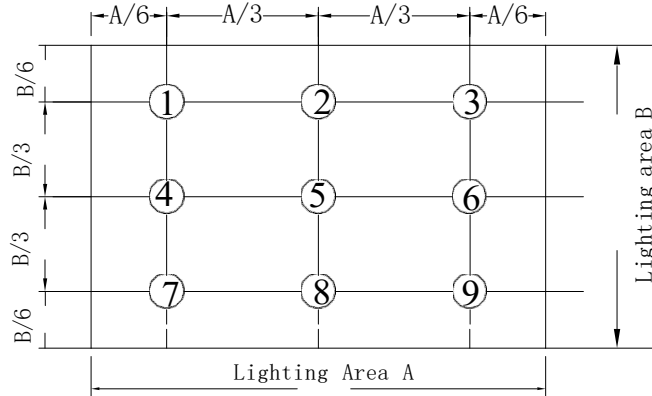

$B_{max}$ : The measured maximum luminance of all measurement position.

$B_{min}$ : The measured minimum luminance of all measurement position.

**7. RELIABILITY TEST ITEMS**

**7.1 TEMPERATURE AND HUMIDITY**

Test Item	Test Condition	Remark
High Temperature Storage	$T_a=80^{\circ}C$ ; 96hrs	IEC60068-2-1: 2007 GB2423.2-2008
Low Temperature Storage	$T_a=-30^{\circ}C$ ;96hrs	IEC60068-2-1: 2007 GB2423.1-2008
High Temperature Operation	$T_a=70^{\circ}C$ ; 96Hrs	IEC60068-2-1: 2007 GB2423.2-2008
Low Temperature Operation	$T_a=-20^{\circ}C$ ; 96hrs	IEC60068-2-1: 2007 GB2423.1-2008
High Temperature High Humidity Operation	$T_a=60^{\circ}C$ , 90%RH, 96Hrs(no condensation)	IEC60068-2-78: 2001 GB/T2423.3-2006
Thermal Shock	$-30^{\circ}C$ (0.5h) ~ $80^{\circ}C$ (0.5h) / 72 cycles	Start with cold temperature , End with high temperature, IEC60068-2-14:1984,GB2423.22-2002
Image Sticking	$25^{\circ}C$ ; 1hrs	Note1

Note1:Condition of image sticking test : $25^{\circ}C \pm 2^{\circ}C$

Operation with test pattern sustained for 1 hrs,then change to gray pattern immediately.after 5 mins,the mura must be disappeared completely

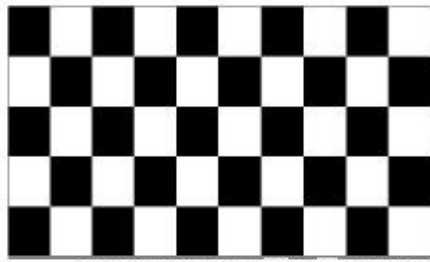

(a) Test Pattern (chess board Pattern )



(b) Gray Pattern

## 7.2 VIBRATION&SHOCK

Test item	Conditions	Remark
Packing Shock (non-operation)	980m/s <sup>2</sup> ,6ms, ±x,y,z 3times for direction	IEC60068-2-27: 1987 GB/T2423.5-1995
Packing Vibration (non-operation)	Frequency range:10 HZ~50HZ Stroke:1.0mm,sweep:10 HZ ~50HZ x,y,z 2 hours for each direction	IEC60068-2-32: 1990 GB/T2423.8-1995

## 7.3 ESD

Test item	Conditions	Remark	
Electro Static Discharge Test (non-operation)	150pF, 330Ω, Contact:±4KV,Air:±8KV	1	Class C
	200pF, 0Ω, ±200V contact test	2	

Note: Measure point :

1. LCD glass and metal bezel
2. IF connector pins
3. ESD class B:some performance degradation allowed. Self-recoverable.  
No data lost,no hardware failures.

## 8. GENERAL PRECAUTION

### 8.1 SAFETY

1. Do not swallow any liquid crystal, even if there is no proof that liquid crystal is poisonous.
2. If the LCD panel breaks, be careful not to get liquid crystal to touch your skin.
3. If skin is exposed to liquid crystal, wash the area thoroughly with alcohol or soap.

### 8.2 STORAGE CONDITIONS

1. Store the panel or module in a dark place where the temperature is  $23 \pm 5^{\circ}\text{C}$  and The humidity is below  $50 \pm 20\% \text{RH}$ .
2. Store in anti-static electricity container.
3. Store in clean environment, free from dust, active gas, and solvent.
4. Do not place the module near organics solvents or corrosive gases.
5. Do not crush, shake, or jolt the module.

### 8.3 HANDLING PRECAUTIONS

1. Avoid static electricity which can damage the CMOS LSI.
2. The polarizing plate of the display is very fragile. So, please handle it very carefully.
3. Do not give external shock.
4. Do not apply excessive force on the surface.
5. Do not wipe the polarizing plate with a dry cloth, as it may easily scratch the Surface of plate.
6. Do not use ketonics solvent & Aromatic solvent, use with a soft cloth soaked with a

---

cleaning naphtha solvent.

7. Do not operate it above the absolute maximum rating.
8. Do not remove the panel or frame from the module.
9. When the module is assembled, it should be attached to the system firmly, Be careful not to twist and bend the module.
10. Wipe off water droplets or oil immediately. If you leave the droplets for a long time, staining and discoloration may occur.
11. If the liquid crystal material leaks from the panel, it should be kept away from the eyes or mouth in case of contact with hands, legs or clothes, it must be washed away thoroughly with soap.

#### **8.4 WARRANTY**

1. The period is within twelve months since the date of shipping out under normal using and storage conditions.
2. Do not repaired or modified the LCM. It may cause function to lose efficacy, Starry does not warrant the LCM.
3. All process and material comply ROHS.

## 1. Incoming inspection right

- (1) The Incoming Inspection Standard will be agreed and signed by both sides (Customer and starry)

## 2. Inspection condition is as follows

- (1) Viewing distance is approximately 35-40 cm
- (2) Viewing angle is normal to the LCD panel as Fig-1 (30°)
- (3) Ambient temperature is approximately  $25 \pm 5^\circ\text{C}$
- (4) Ambient humidity is  $60 \pm 5\% \text{RH}$
- (5) Ambient illuminance is from 300-500 Lux
- (6) Input signal timing should be typical value
- (7) Mura & Light leakage inspection an ND-Filter 5%

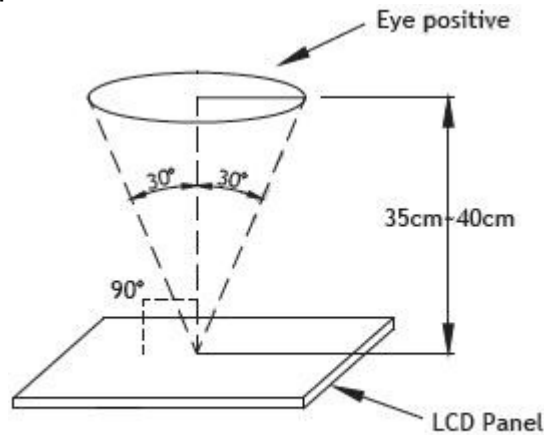

Fig-1

## 3. Special condition

- (1) Viewing distance is close for inspection of adjacent dots and distance between defect Dots
- (2) Viewing condition of “Shot block non-uniformity from oblique angle” is as Fig-2
- (3) Exceptional case: View angle  $\pm 40^\circ$  while inspected image-sticking

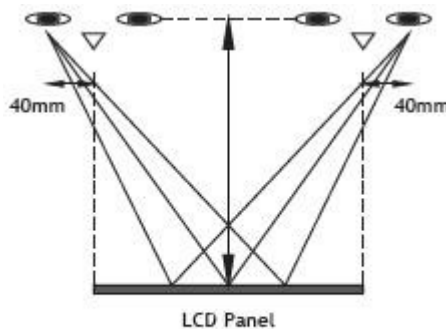
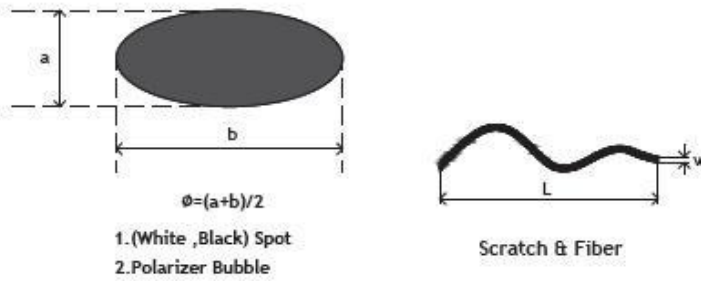

Fig-2

### 4. INSPECTION CRITERIA

Defecttype		Limit			Note	
Visual defect	Scratch	$W \leq 0.05\text{mm}$		Ignore	Note1	
		$0.05\text{mm} \leq w \leq 0.1\text{m}$		$N \leq 3$		
		$L \leq 10\text{mm}$				
		$20\text{mm} < l, 0.1\text{mm} < w$		$N=0$		
	Internal	Spot	$\Phi < 0.3\text{mm}$		Ignore	Note 1
			$0.3\text{mm} \leq \phi \leq 0.4\text{mm}$		$N \leq 3$	
			$0.4 \leq \phi$		$N=0$	
		Fiber	$0.1\text{mm} \leq w \leq 0.2\text{m}$		$N \leq 4$	Note 1
			$L \leq 2.5\text{mm}$			
		$0.2\text{mm} < w, 2.5\text{mm} < l$		$N=0$		
		Polarizer bubble	$\Phi < 0.3\text{mm}$		Ignore	Note 1
			$0.25\text{mm} \leq \phi \leq 0.5\text{mm}$		$N \leq 2$	
			$0.5 \leq \phi$		$N=0$	
		Dent	$\Phi < 0.25\text{mm}$		Ignore	Note 1
			$0.25\text{mm} \leq \phi \leq 0.5\text{mm}$		$N \leq 4$	
$0.5 \leq \phi$			$N=0$			
Electrical Defect	Bright dot	C area	O area	Total	Note 2 Note 3 use of ND5 % invisible OK	
		$N \leq 1$	$N \leq 2$	$N \leq 3$		
	Dark dot	$N \leq 2$	$N \leq 4$	$N \leq 4$		
	Total dot	$N \leq 3$	$N \leq 4$	$N \leq 4$		
	Dense point	Using ND5 % visible by intensive foreign standard judgement, ND5 % invisible OK				Note 4
		<div style="display: flex; justify-content: space-around; margin-top: 10px;"> <div style="border: 1px solid black; padding: 5px; text-align: center;">             D=2mm, 点4 判定OK         </div> <div style="border: 1px solid black; padding: 5px; text-align: center;">             D=2mm, 点6 个为密集点NG         </div> </div>				
<p>(1) One pixel consists of 3 sub-pixel, including r, g, and b dot. (sub-pixel=dot)</p> <p>(2) Panel is acceptable if distance between 2 dot defects are greater or equal to 5mm.</p>						

Note1 : W : Width[mm], L : Length[mm], N : Number,  $\varphi$ : Average Diameter



Note2 : Bright dot is defined as the defective area of the dot is larger than 50% of one sub-pixel area.

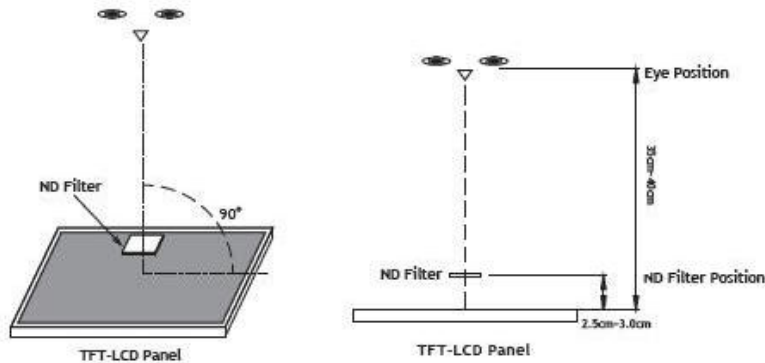

Note3 :

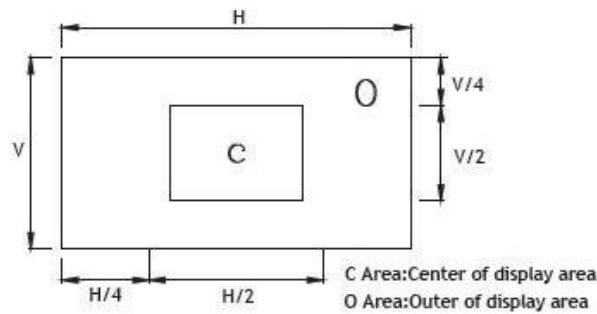

Note4 : Judge defect dot and adjacent dot as following. Allow below (as A, B, C and D status) adjacent defect dots, including bright and dart adjacent dot. And they will be counted 2 defect dots in total quantity.

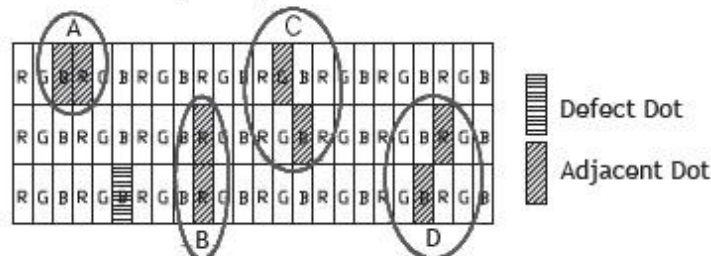

Note5 : Other condition

- (1) The defects that are not defined above and considered to be problem shall be reviewed and discussed by both parties.
- (2) Defects on the Black Matrix, out of Display area, are not considered as a defect or counted.

## 5. HANDLING PRECAUTION

- (1) Don't disassemble and reassemble the module by self.  
(禁止自行拆解)
- (2) Acid, alkali, alcohol or touched directly by hand will damage the display.  
(酸性、碱性、酒精或手的直接接触将会损伤显示面)
- (3) Static electricity will damage the module. Please configure grounding device.  
(静电会损伤模组，请装配接地设备)
- (4) The strong vibration, shock, twist or bend will cause material damage, even module broken.  
(强烈的撞击、震动、扭转或弯曲将会造成原材损伤，甚至面板破裂)
- (5) It is easy to cause image sticking while displaying the same pattern for very long time.  
(长期显示同一画面会造成影像残留)
- (6) The response time, brightness and performance will vary from different temperature.  
(响应时间、亮度与均匀性会因温度而有所改变)
- (7) The Period is within 12 months since the date of shipping out under normal using and Storage conditions.  
(从出货之日开始,在正常使用和存储条件下，产品保质期为 12 个月)

### 9.Cardboard box packaging method

