

## SPECIFICATION FOR APPROVAL

**DESCRIPTION:** 8 LCD Module \_\_\_\_\_

**CUSTOMER:** \_\_\_\_\_

**Product No:** BR080SIE3064-A4 V.1 \_\_\_\_\_

**Released Date:** 2019/05/31 \_\_\_\_\_

**Revision:** 0.1 \_\_\_\_\_

PLEASE RETURN TO US ONE COPY OF "SPECIFICATION FOR APPROVAL" WITH YOUR APPROVED SIGNATURES.

APPROVED SIGNATURES			

### Record of Revision

Version	Revise Date	Page	Content
Final-Spec.01	2019/05/31		Initial Release.

## Contents

1. General Specifications .....	1
2. Pin Assignment .....	2
2.1. TFT LCD Panel Driving Section .....	2
2.2. Backlight Unit Section .....	5
3. Operation Specifications .....	6
3.1. Absolute Maximum Rating .....	6
3.1.1. Typical Operation Conditions .....	7
3.1.2. Current Consumption .....	8
3.1.3. Backlight Driving Conditions .....	8
3.2. Power Sequence .....	9
3.3. Timing Characteristics .....	10
3.3.1. AC Electrical Characteristics .....	10
3.3.2. Timing .....	11
3.3.3. Timing Diagram .....	12
4. Optical Specifications .....	13
5. Reliability Test Items .....	17
6. General Precautions .....	18
6.1. Safety .....	18
6.2. Handling .....	18
6.3. Static Electricity .....	18
6.4. Storage .....	18
6.5. Cleaning .....	18
7. Mechanical Drawing .....	19
8. Package Drawing .....	20
8.1 Packaging Material Table .....	20
8.2 Packaging Quantity .....	20
8.3 Packaging Drawing .....	21

# 1. General Specifications

No.	Item	Specification	Remark
1	LCD size	8.0 inch(Diagonal)	
2	Driver element	a-Si TFT active matrix	
3	Resolution	800 × 3(RGB) × 600	
4	Display mode	Normally White, Transmissive	
5	Dot pitch	0.0675(W) × 0.2025(H) mm	
6	Active area	162.0(W) × 121.5(H) mm	
7	Module size	183.0(W) × 141.0(H) × 6.3(D) mm	Note 1
8	Surface treatment	Anti-Glare	
9	Color arrangement	RGB-stripe	
10	Interface	Digital	
11	Backlight power consumption	1.782W (Typ.)	
12	Panel power consumption	0.356W (Typ.)	
13	Weight	258g (Typ.)	

Note 1: Refer to Mechanical Drawing.

## 2. Pin Assignment

### 2.1. TFT LCD Panel Driving Section

1. FPC Connector is used for the module electronics interface. The recommended model is FH12A-50S-0.5SH manufactured by Hirose.
2. LED Light Bar Connector is used for the integral backlight system. The recommended model is BHSR-02VS-1 manufactured by JST.

Pin No.	Symbol	I/O	Function	Remark
1	NC		No connection	
2	NC		No connection	
3	NC		No connection	
4	NC		No connection	
5	GND	P	Power ground	
6	V <sub>COM</sub>	I	Common voltage	
7	V <sub>CC</sub>	P	Power for Digital circuit	
8	MODE	I	DE/SYNC mode select	Note3
9	DE	I	Data Input Enable	
10	VS	I	Vertical Sync Input	
11	HS	I	Horizontal Sync Input	
12	B7	I	Blue data(MSB)	
13	B6	I	Blue data	
14	B5	I	Blue data	
15	B4	I	Blue data	
16	B3	I	Blue data	
17	B2	I	Blue data	
18	B1	I	Blue data	
19	B0	I	Blue data(LSB)	
20	G7	I	Green data (MSB)	
21	G6	I	Green data	
22	G5	I	Green data	
23	G4	I	Green data	
24	G3	I	Green data	
25	G2	I	Green data	
26	G1	I	Green data	
27	G0	I	Green data (LSB)	
28	R7	I	Red data (MSB)	
29	R6	I	Red data	
30	R5	I	Red data	

31	R4	I	Red data	
32	R3	I	Red data	
33	R2	I	Red data	
34	R1	I	Red data	
35	R0	I	Red data (LSB)	
36	GND	P	Power ground	
37	DCLK	I	Sample clock	
38	GND	P	Power ground	
39	L/R	I	Right/ left selection	Note2,5
40	U/D	I	Up/down selection	Note2,5
41	V <sub>GH</sub>	P	Gate ON voltage	
42	V <sub>GL</sub>	P	Gate OFF voltage	
43	AV <sub>DD</sub>	P	Power for Analog circuit	
44	RESET	I	Global reset pin.	Note1
45	NC		No connection	
46	V <sub>COM</sub>	I	Common voltage	
47	DITHB	I	Dithering function	Note 4
48	GND	P	Power ground	
49	NC		No connection	
50	NC		No connection	

I: input, O: output, P: Power

Note 1: Global reset pin. Active Low to enter Reset State. Suggest to connecting with an RC reset circuit for stability. Normally pull high.

Note 2: Selection of scanning mode

Setting of scan control input		Scanning direction
U/D	R/L	
GND	V <sub>CC</sub>	Up to down, left to right
V <sub>CC</sub>	GND	Down to up, right to left
GND	GND	Up to down, right to left
V <sub>CC</sub>	V <sub>CC</sub>	Down to up, left to right

Note 3: DE/SYNC mode select, Normally pull high.

H: DE mode.

L: HS/VS mode.

Note4: Dithering function enable control. Normally pull high.

DITHB="1", Disable internal dithering function. For 18bit RGB interface, connect two LSB bits of all the R/G/B data buses to GND.

DITHB="0", Enable internal dithering function, For TTL 24bit parallel RGB image data input.

Note 5: Definition of scanning direction.  
Refer to the figure as below:

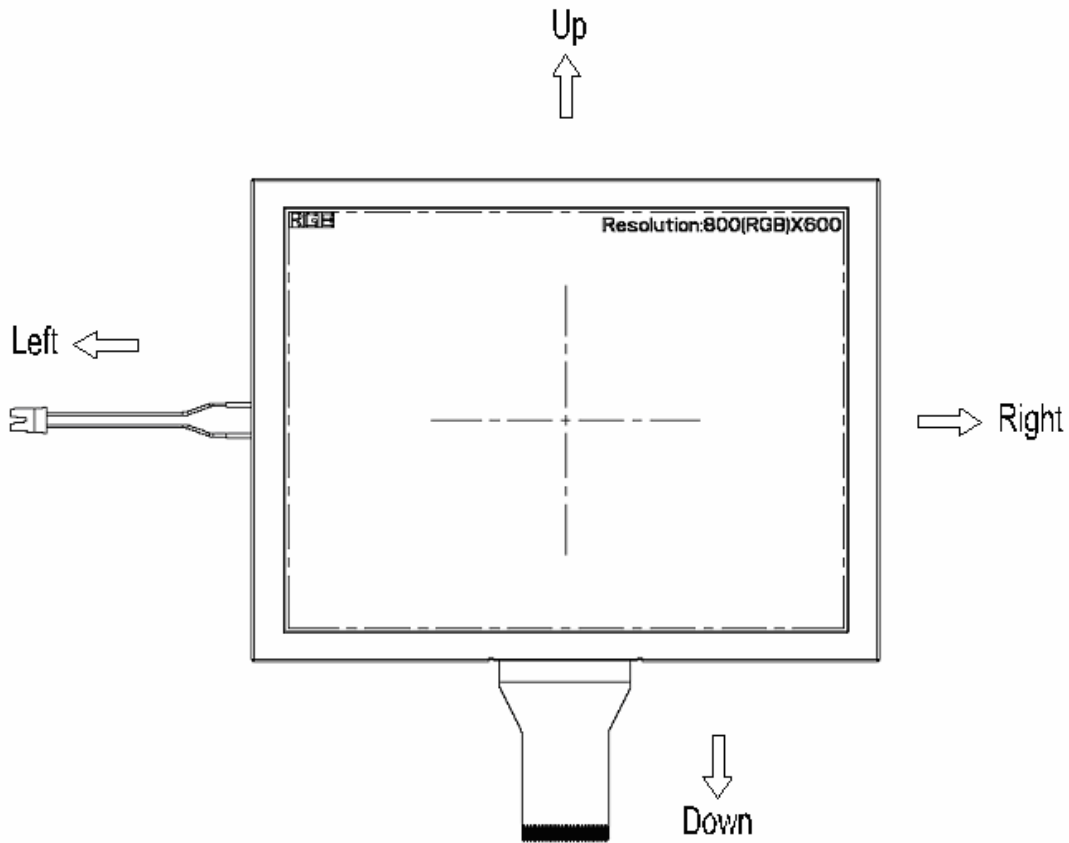

## 2.2. Backlight Unit Section

Pin No.	Symbol	I/O	Function	Remark
1	V <sub>LED+</sub>	P	Power for LED backlight anode	Pink
2	V <sub>LED-</sub>	P	Power for LED backlight cathode	Black



## 3. Operation Specifications

### 3.1. Absolute Maximum Rating

(GND=AV<sub>SS</sub>=0V, Note 1)

Item	Symbol	Values		Unit	Remark
		Min.	Max.		
Power voltage	V <sub>CC</sub>	-0.3	5.0	V	
	AV <sub>DD</sub>	-0.5	13.5	V	
	V <sub>GH</sub>	13.0	19.0	V	
	V <sub>GL</sub>	-12.0	-2.0	V	
	V <sub>GH</sub> -V <sub>GL</sub>	-	31.0	V	
Operation Temperature Storage Temperature	T <sub>OP</sub>	-20	70	°C	
	T <sub>ST</sub>	-30	80	°C	
LED Reverse Voltage	V <sub>R</sub>	-	1.2	V	each LED Note 2
LED Forward Current	I <sub>F</sub>	-	25	mA	each LED

Note 1: The absolute maximum rating values of this product are not allowed to be exceeded at any times. Should a module be used with any of the absolute maximum ratings exceeded, the characteristics of the module may not be recovered, or in an extreme case, the module may be permanently destroyed.

Note 2: V<sub>R</sub> Conditions: Zener Diode 20mA

### 3.1.1. Typical Operation Conditions

 (GND=AV<sub>SS</sub>=0V, Note 1)

Item	Symbol	Values			Unit	Remark
		Min.	Typ.	Max.		
Power voltage	V <sub>CC</sub>	3.0	3.3	3.6	V	Note 2
	AV <sub>DD</sub>	10.2	10.4	10.6	V	
	V <sub>GH</sub>	15.3	16.0	16.7	V	
	V <sub>GL</sub>	-7.7	-7.0	-6.3	V	
Input signal voltage	V <sub>COM</sub>	3.5	3.7	3.9	V	
Input logic high voltage	V <sub>IH</sub>	0.7V <sub>CC</sub>	-	V <sub>CC</sub>	V	Note 3
Input logic low voltage	V <sub>IL</sub>	0	-	0.3V <sub>CC</sub>	V	

Note 1: Be sure to apply V<sub>CC</sub> and V<sub>GL</sub> to the LCD first, and then apply V<sub>GH</sub>.

Note 2: V<sub>CC</sub> setting should match the signals output voltage (refer to Note 3) of customer's system board .

Note 3: DCLK,HS,VS,RSTB,UPDN,STLR,MODE,DITHB.

### 3.1.2. Current Consumption

(GND=AV<sub>SS</sub>=0V)

Item	Symbol	Values			Unit	Remark
		Min.	Typ.	Max.		
Current for Driver	I <sub>GH</sub>	-	0.2	0.5	mA	V <sub>GH</sub> =16.0V
	I <sub>GL</sub>	-	0.2	1.0	mA	V <sub>GL</sub> = -7.0V
	I <sub>CC</sub>	-	5.5	10.0	mA	V <sub>CC</sub> =3.3V
	I <sub>AVDD</sub>	-	32.0	50.0	mA	AV <sub>DD</sub> =10.4V

### 3.1.3. Backlight Driving Conditions

Item	Symbol	Values			Unit	Remark
		Min.	Typ.	Max.		
Voltage for LED backlight	V <sub>L</sub>	9.3	9.9	10.5	V	Note 1
Current for LED backlight	I <sub>L</sub>	250	300	350	mA	
LED life time	-	20,000	-	-	Hr	Note 2

Note 1: The LED Supply Voltage is defined by the number of LED at Ta=25°C and I<sub>L</sub> =250mA.

Note 2: The “LED life time” is defined as the module brightness decrease to 50% original brightness at Ta=25°C and I<sub>L</sub> =250mA. The LED lifetime could be decreased if operating I<sub>L</sub> is larger than 250 mA.

## 3.2. Power Sequence

### 3.2.1. Power on:

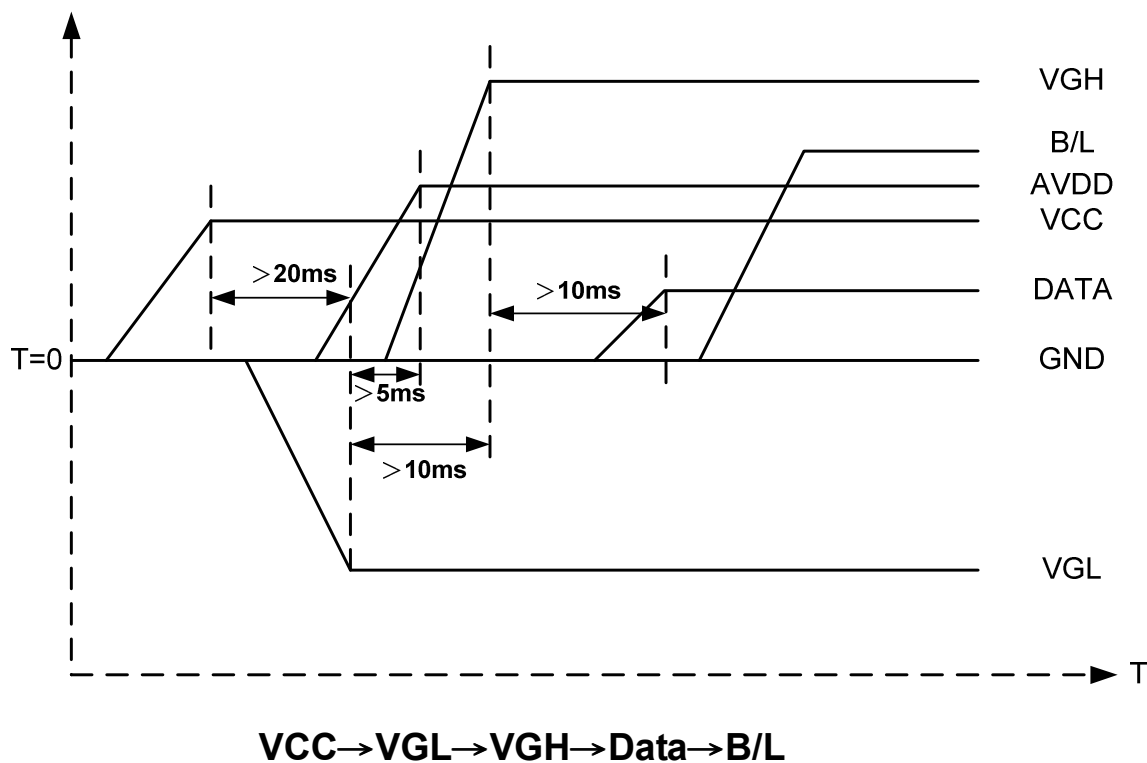

### 3.2.2. Power off:

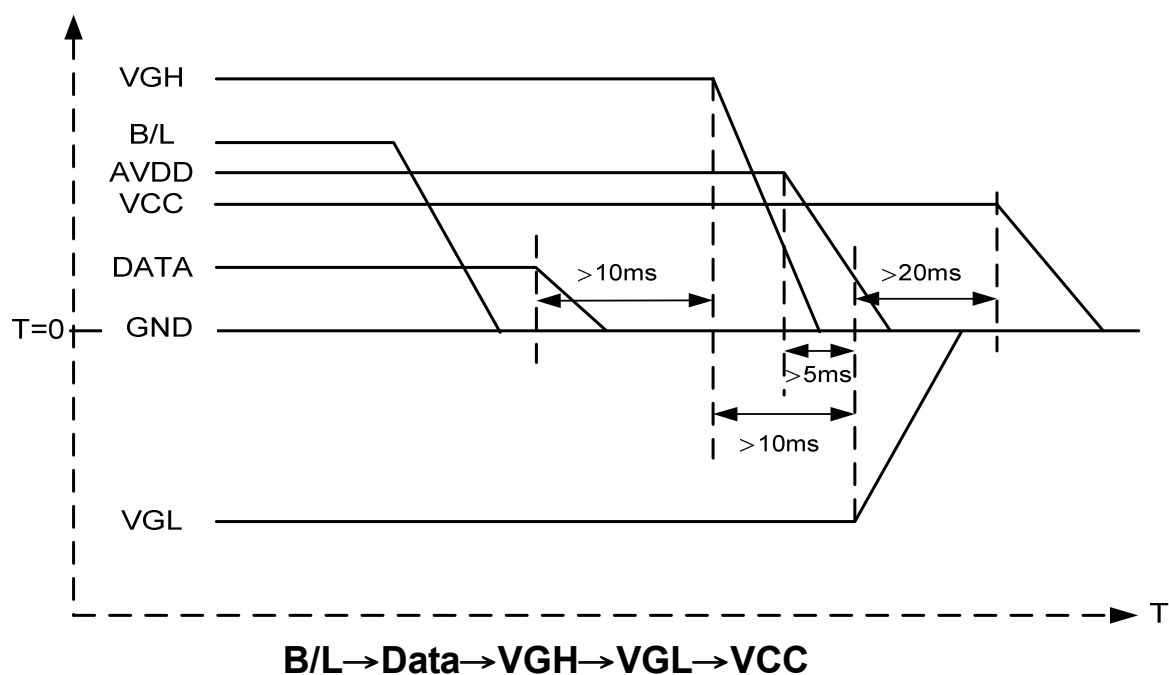

Note: Data include R0~R5, B0~B5, GO~G5, STLR,UPDN, DCLK, HS,VS,DE.

### 3.3. Timing Characteristics

#### 3.3.1. AC Electrical Characteristics

Item	Symbol	Values			Unit	Remark
		Min.	Typ.	Max.		
HS setup time	$T_{hst}$	8	-	-	Ns	
HS hold time	$T_{hhd}$	8	-	-	Ns	
VS setup time	$T_{vst}$	8	-	-	Ns	
VS hold time	$T_{vhd}$	8	-	-	Ns	
Data setup time	$T_{dsu}$	8	-	-	Ns	
Data hole time	$T_{dhd}$	8	-	-	Ns	
DE setup time	$T_{esu}$	8	-	-	Ns	
DE hole time	$T_{ehd}$	8	-	-	Ns	
VDD Power On Slew rate	$T_{POR}$	-	-	20	ms	
RSTB pulse width	$T_{Rst}$	10	-	-	us	
CLKIN cycle time	$T_{coh}$	20	-	-	Ns	
CLKIN pulse duty	$T_{cwh}$	40	50	60	%	
Output stable time	$T_{sst}$	-	-	6	us	

### 3.3.2. Timing

Item	Symbol	Values			Unit	Remark
		Min.	Typ.	Max.		
Horizontal Display Area	thd	-	800	-	DCLK	
DCLK Frequency	fclk	-	40	50	MHz	
One Horizontal Line	th	862	1056	1200	DCLK	
HS pulse width	thpw	1	-	40	DCLK	
HS Back Porch(Blanking)	thb	46	46	46	DCLK	
HS Front Porch	thfp	16	210	354	DCLK	

Item	Symbol	Values			Unit	Remark
		Min.	Typ.	Max.		
Vertical Display Area	tvd	-	600	-	TH	
VS period time	tv	624	635	700	TH	
VS pulse width	tvpw	1	-	20	TH	
VS Back Porch(Blanking)	tvb	23	23	23	TH	
VS Front Porch	tvfp	1	12	77	TH	

### 3.3.3. Timing Diagram

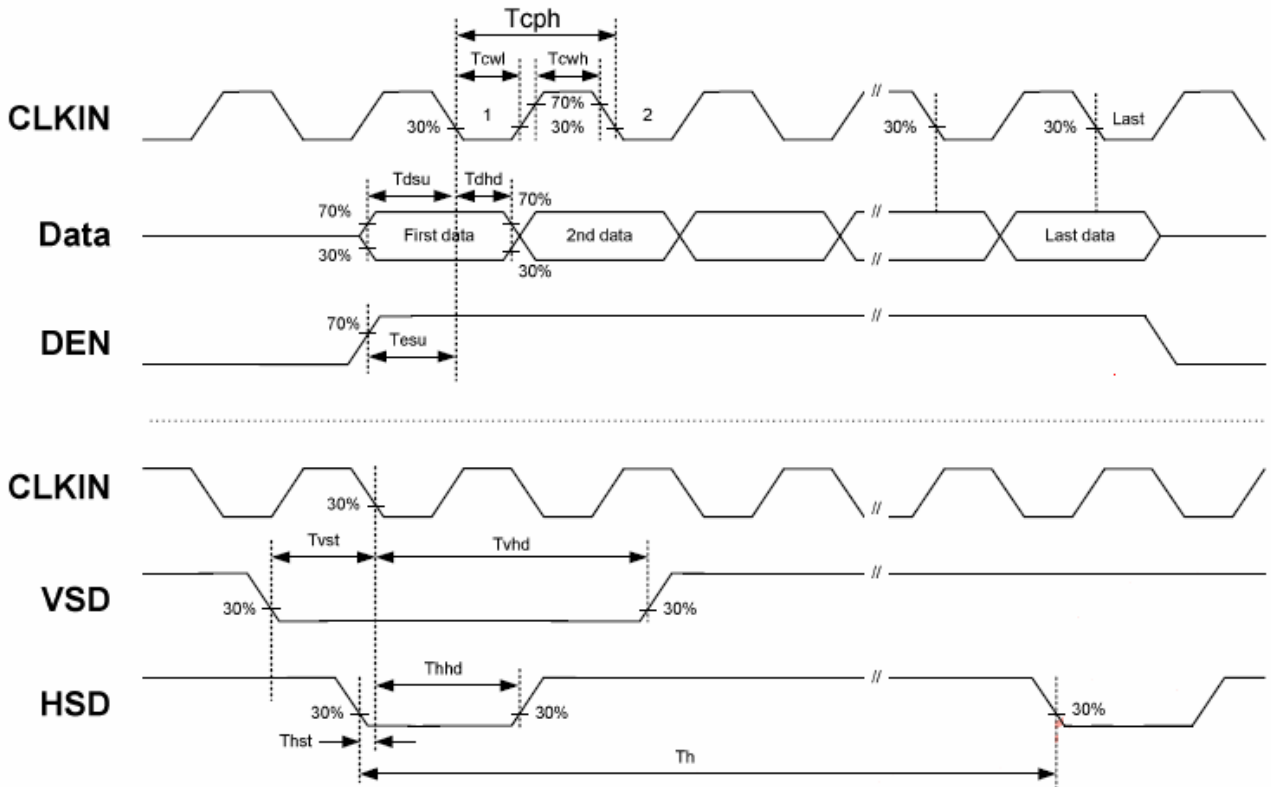

Figure 3.1 Input Clock and Data Timing Diagram

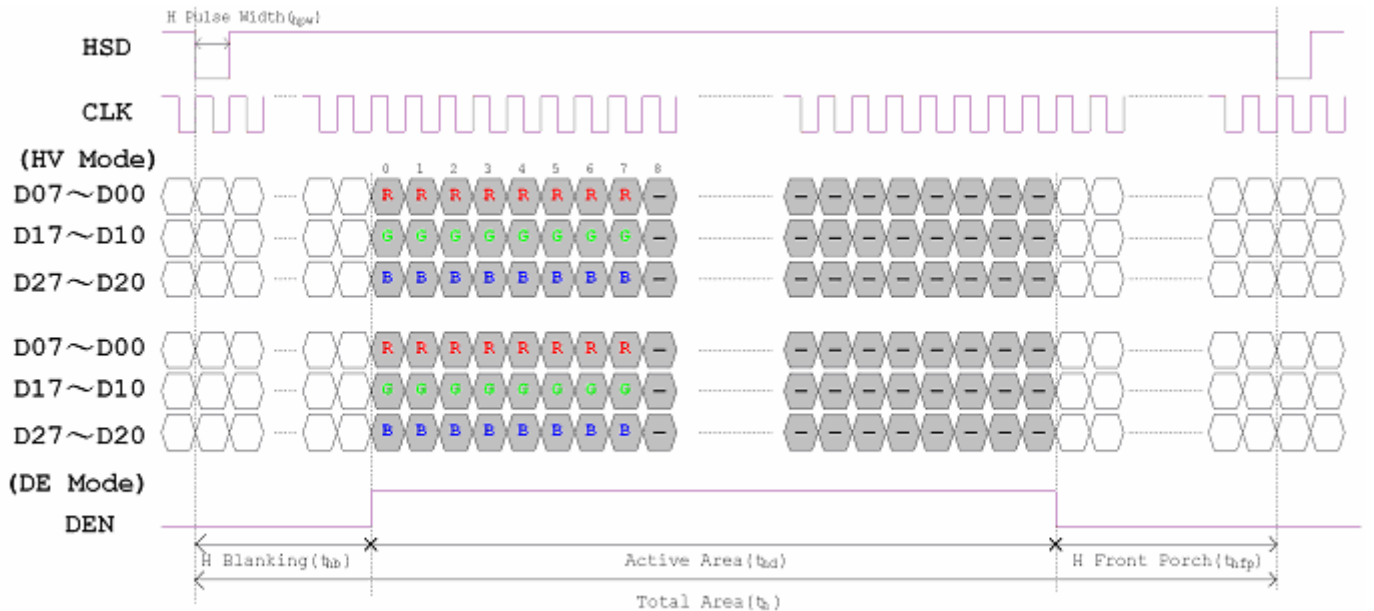

Figure 3.2 Horizontal input timing diagram.

## 4. Optical Specifications

Item	Symbol	Condition	Values			Unit	Remark
			Min.	Typ.	Max.		
Viewing angle (CR≥ 10)	$\theta_L$	$\Phi=180^\circ$ (9 o'clock)	60	70	-	degree	Note 1
	$\theta_R$	$\Phi=0^\circ$ (3 o'clock)	60	70	-		
	$\theta_T$	$\Phi=90^\circ$ (12 o'clock)	40	50	-		
	$\theta_B$	$\Phi=270^\circ$ (6 o'clock)	60	70	-		
Response time	$T_{ON}$	Normal $\theta=\Phi=0^\circ$	-	10	20	msec	Note 3
	$T_{OFF}$		-	15	30	msec	Note 3
Contrast ratio	CR		400	500	-	-	Note 4
Color chromaticity	$W_X$		0.26	0.31	0.36	-	Note 2 Note 5 Note 6
	$W_Y$		0.28	0.33	0.38	-	
Luminance	L		350	400	-	cd/m <sup>2</sup>	Note 6
Luminance uniformity	$Y_U$		70	75	-	%	Note 7

### Test Conditions:

1.  $V_{CC}=3.3V$ ,  $I_L=250mA$  (Backlight current), the ambient temperature is  $25^\circ C$ .
2. The test systems refer to Note 2.



Note 1: Definition of viewing angle range

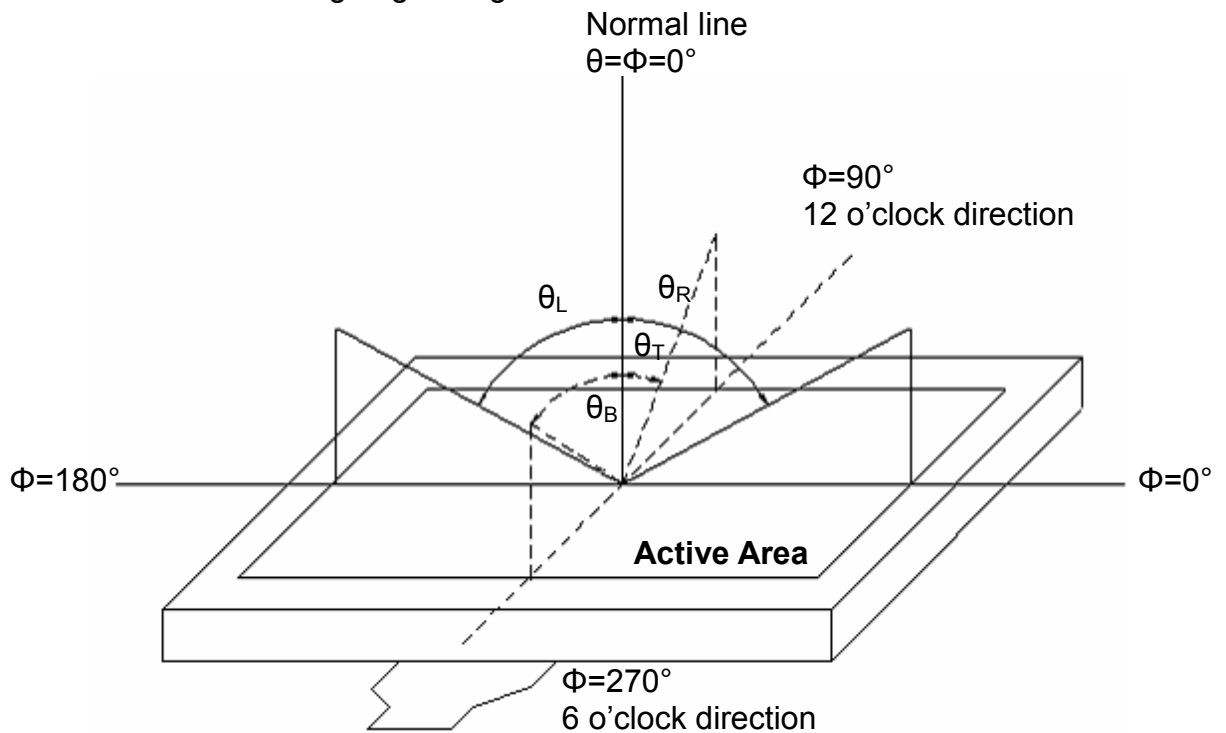

Fig. 4-1 Definition of viewing angle

Note 2: Definition of optical measurement system.

The optical characteristics should be measured in dark room. After 30 minutes operation, the optical properties are measured at the center point of the LCD screen. (Response time is measured by Photo detector TOPCON BM-7, other items are measured by BM-5A/Field of view:  $1^\circ$  /Height: 500mm.)

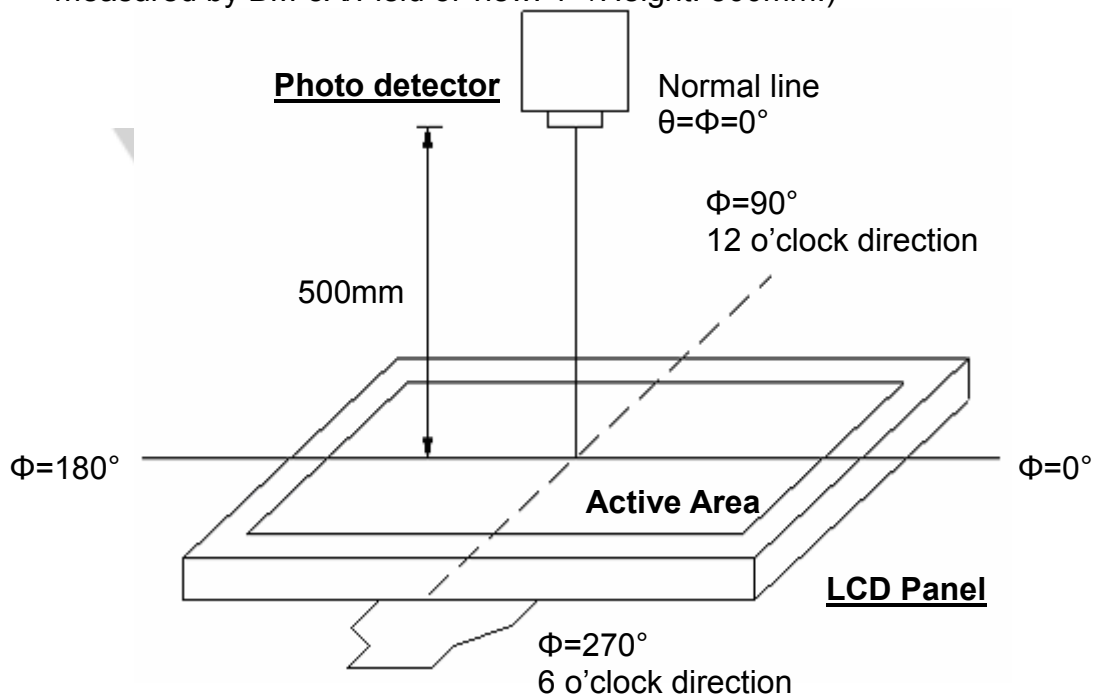

Fig. 4-2 Optical measurement system setup

Note 3: Definition of Response time

The response time is defined as the LCD optical switching time interval between "White" state and "Black" state. Rise time ( $T_{ON}$ ) is the time between photo detector output intensity changed from 90% to 10%. And fall time ( $T_{OFF}$ ) is the time between photo detector output intensity changed from 10% to 90%.

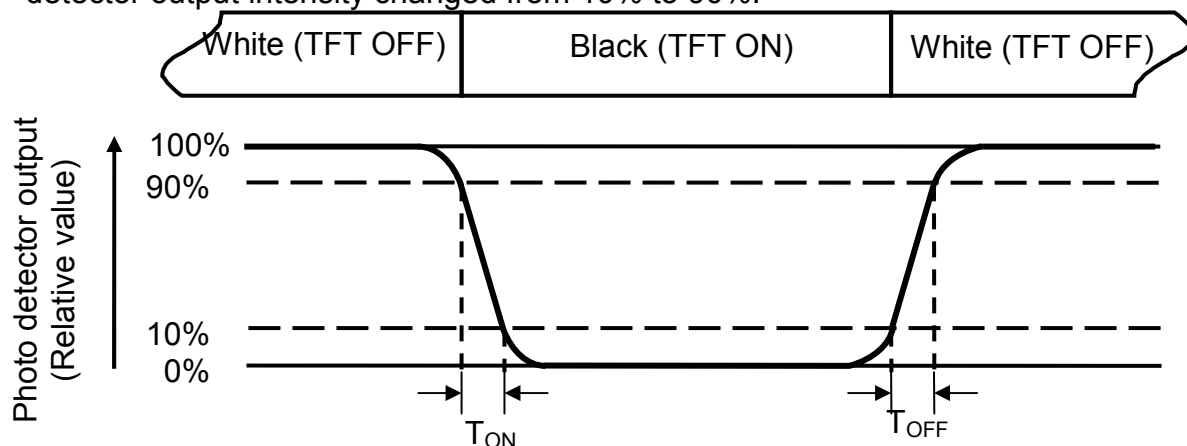

Fig. 4-3 Definition of response time

Note 4: Definition of contrast ratio

$$\text{Contrast ratio (CR)} = \frac{\text{Luminance measured when LCD on the "White" state}}{\text{Luminance measured when LCD on the "Black" state}}$$

Note 5: Definition of color chromaticity (CIE1931)

Color coordinates measured at center point of LCD.

Note 6: All input terminals LCD panel must be ground while measuring the center area of the panel. The LED driving condition is  $I_L=250\text{mA}$ .

Note 7: Definition of Luminance Uniformity

Active area is divided into 9 measuring areas (Refer to Fig. 4-4 ).Every measuring point is placed at the center of each measuring area.

$$\text{Luminance Uniformity (Yu)} = \frac{B_{min}}{B_{max}}$$

L-----Active area length      W----- Active area width

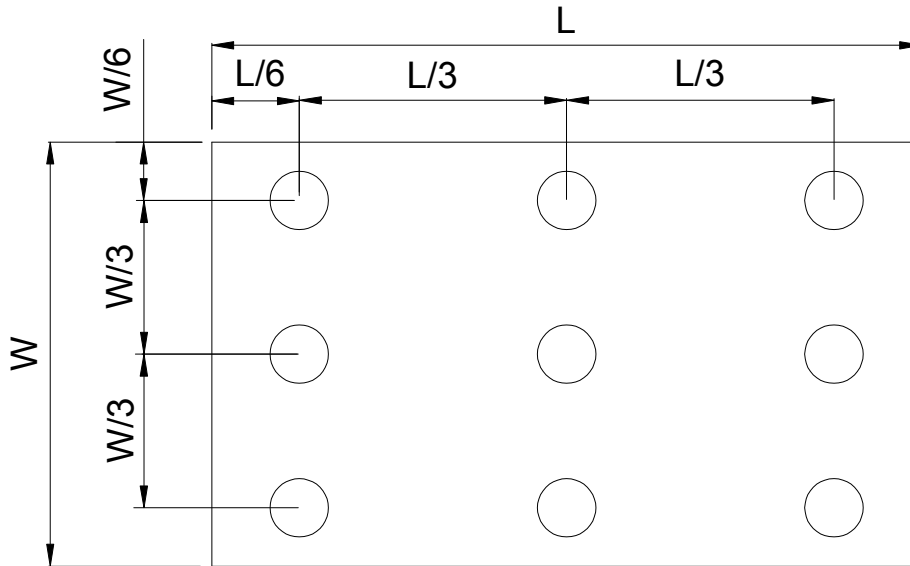
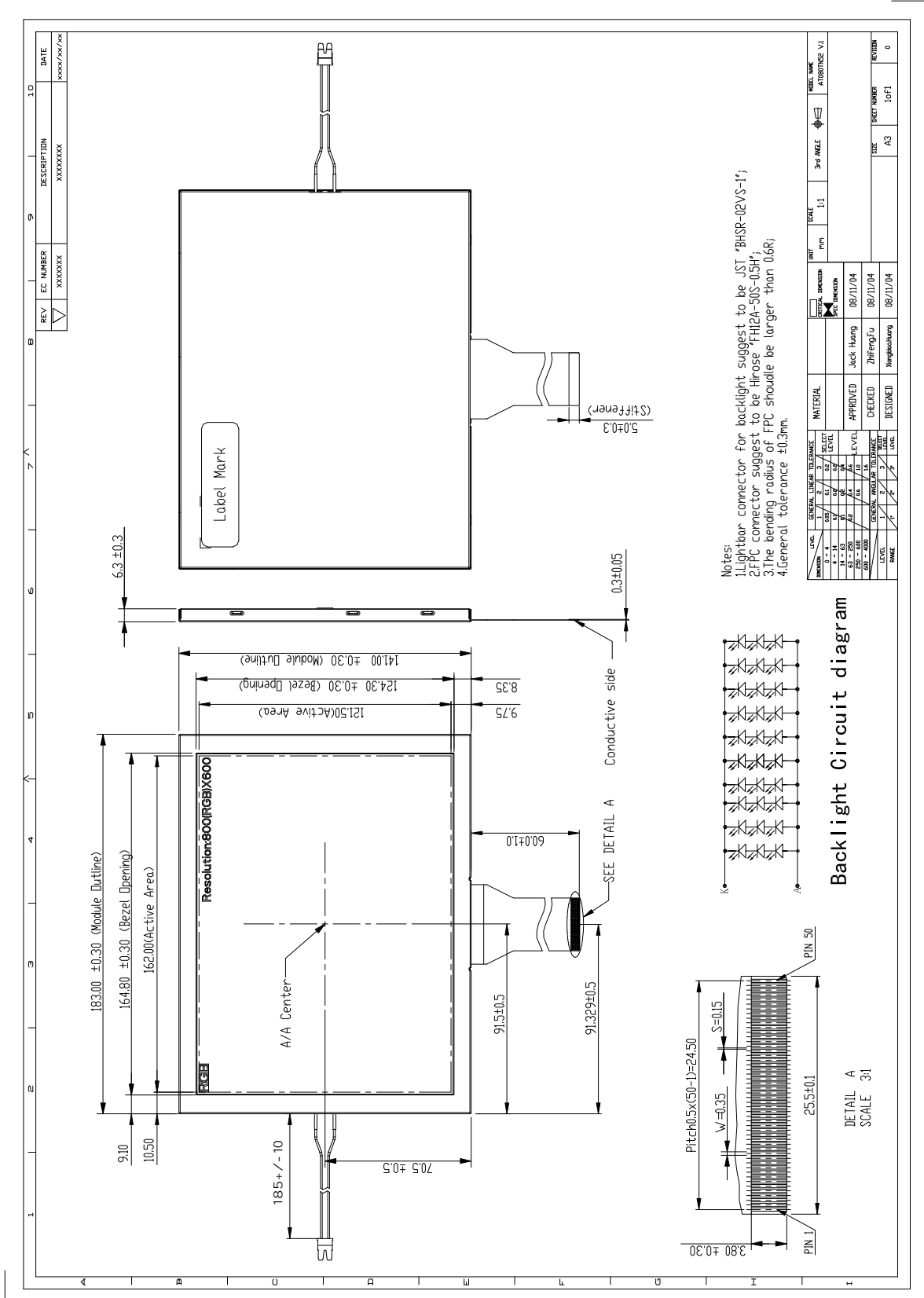

Fig. 4-4 Definition of measuring points

**B<sub>max</sub>**: The measured maximum luminance of all measurement position.  
**B<sub>min</sub>**: The measured minimum luminance of all measurement position.



# 7. Mechanical Drawing



## 9.0 BOM LIST

( TBD )

## 10.0 LOT MARK

### 10.1 Location of Lot Mark

- (1) Location: The label is attached to the backside of the LCD module.
- (2) Detail of the Mark: as attached below.
- (3) This is subject to change without prior notice.



# 11.0 PACKAGE SPECIFICATION

## 11.1 Packing form

LCM Model	LCM Qty. in the box	Inner Box Size ( mm )	Note
080S IE3064-A4 V.1	60 pcs/box	490±5 x 340±5 x 250±5	

## 11.2 Packing assembly drawings

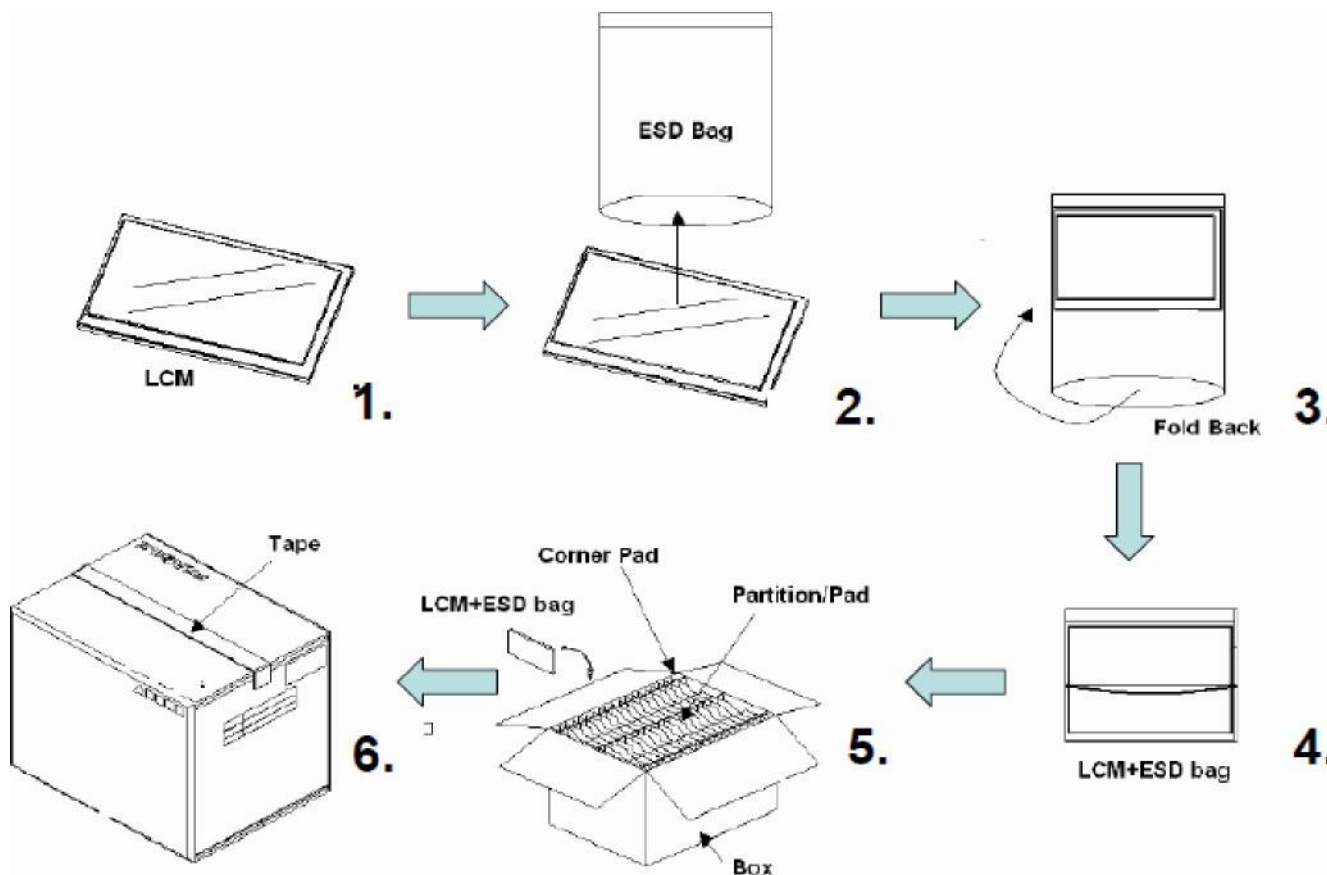

Items	Material	Notice
Box	Corrugated Paper Board	AB Flute
Partition/Pad	Corrugated Paper Board	B Flute
Corner Pad	Corrugated Paper Board	AB Flute
ESD bag	PE	

- 12.2.2.1 Housing case must be destined carefully so as not to put stresses on LCD all sides and not to wrench module. The stresses may cause non-uniformity even if there is no non-uniformity statically.
- 12.2.2.2 Keep sufficient clearance between LCD module back surface and housing when the LCD module is mounted. The clearance in the design is recommended taking into account the tolerance of LCD module thickness and mounting structure height on the housing.
- 12.2.3 Please do not push or scratch LCD panel surface with any-thing hard. And do not soil LCD panel surface by touching with bare hands.(Polarizer film, surface of LCD panel is easy to be flawed.)
- 12.2.4 Please do not press any parts on the rear side such as source IC, gate IC, and FPC during handling LCD module, If pressing rear part is unavoidable, handle the LCD module with care not to damage them.
- 12.2.5 Please wipe out LCD panel surface with absorbent cotton or soft cloth in case of it being soiled.
- 12.2.6 Please wipe out drops of adhesives like saliva and water on LCD panel surface immediately. They might damage to cause panel surface variation and color change.
- 12.2.7 Please do not take a LCD module to pieces and reconstruct it. Resolving and reconstructing modules may cause them not to work well.

### 12.3 Disassembling or Modification

Do not disassemble or modify the module. It may damage sensitive parts inside LCD module, and may cause scratches or dust on the display. Century does not warrant the module, if customers disassemble or modify the module.

### 12.4 Breakage of LCD Panel

- 12.4.1.If LCD panel is broken and liquid crystal spills out, do not ingest or inhale liquid crystal, and do not contact liquid crystal with skin.
- 12.4.2. If liquid crystal contacts mouth or eyes, rinse out with water immediately.
- 12.4.3. If liquid crystal contacts skin or cloths, wash it off immediately with alcohol and rinse thoroughly with water.

12.4.4. Handle carefully with chips of glass that may cause injury, when the glass is broken.

### 12.5 Absolute Maximum Ratings and Power Protection Circuit

- 12.5.1. Do not exceed the absolute maximum rating values, such as the supply voltage variation, input voltage variation, variation in parts' parameters, environmental temperature, etc., otherwise LCD module may be damaged.

12.5.2. Please do not leave LCD module in the environment of high humidity and high temperature for a long time.

12.5.3. It's recommended to employ protection circuit for power supply.

### 12.6 Operation

- 12.6.1 Do not touch, push or rub the polarizer with anything harder than HB pencil lead.
- 12.6.2 Use fingerstalls of soft gloves in order to keep clean display quality, when persons handle the LCD module for incoming inspection or assembly.
- 12.6.3 When the surface is dusty, please wipe gently with absorbent cotton or other soft material.
- 12.6.4 Wipe off saliva or water drops as soon as possible. If saliva or water drops contact with polarizer for a long time, they may causes deformation or color fading.



**12.6.5** When cleaning the adhesives, please use absorbent cotton wetted with a little petroleum benzene or other adequate solvent.

**12.7 Static Electricity**

**12.7.1** Protection film must remove very slowly from the surface of LCD module to prevent from electrostatic occurrence.

**12.7.2.** Because LCD module use CMOS-IC on circuit board and TFT-LCD panel, it is very weak to electrostatic discharge. Please be careful with electrostatic discharge.

**12.7.3** Persons who handle the module should be grounded through adequate methods.

**12.8 Disposal**

When disposing LCD module, obey the local environmental regulations.

**12.9 Others**

**12.9.1** A strong incident light into LCD panel might cause display characteristics' changing inferior because of Polarizer film, color filter, and other materials becoming inferior. Please do not expose LCD module direct sunlight and strong UV rays.

**12.9.2** Please pay attention to a panel side of LCD module not to contact with other materials in pressing it alone.

**12.9.3** For the packaging box, please pay attention to the followings:

**12.9.3.1** Packaging box and inner case for LCD are designed to protect the LCDs from the damage or scratching during transportation. Please do not open except picking LCDs up from the box.

**12.9.3.2** Please do not pile them up more than 6 boxes(They are not designed so) And please do not turn over.

**12.9.3.3** Please handle packaging box with care not to give them sudden shock and vibrations. And also please do not throw them up.

**12.9.3.4** Packing box and inner case for LCDs are made of cardboard, So please pay attention not to get them wet(Such like keeping them in high humidity or wet place can occur getting them wet.)